

User Guide

Version 2



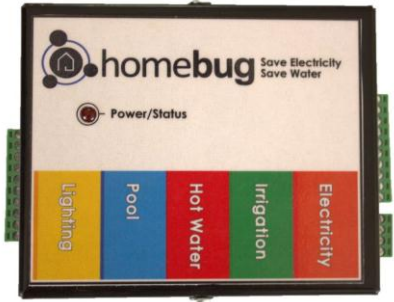





Table of Contents

1 Introduction	1
1.1 Package Contents.....	2
2 Installation.....	3
3 Configuration	4
4 Electricity Usage.....	8
4.1 Pre-Paid meter with LED Pulse output.....	8
4.2 KWh meter Connection.	9
4.3 Calibrate Flasher	10
5 Hot Water	11
6 Pool.....	12
7 Irrigation	13
8 Lighting	14
8.1 Lighting Setup	15
9 Troubleshooting	16
9.1 FAQ.....	16
9.2 Hardware Reset Procedure.....	16

1 Introduction

Thank you for purchasing the Homebug energy and home management system. This quick start guide is designed to get your Homebug connected as quickly as possible and collecting information. Allowing you to start managing your home better.

1.1 Package Contents

 <p>A brown cardboard box with a Homebug logo and QR code on the top right.</p>	<p>Homebug Black Box</p>  <p>The Homebug Black Box is a rectangular device with a white faceplate. It features the Homebug logo and the slogan "Save Electricity Save Water". Below the logo is a "Power/Status" indicator. The front panel has five vertical colored sections: yellow for "Lighting", blue for "Pool", red for "Hot Water", green for "Irrigation", and orange for "Electricity".</p>	
<p>12V DC Power supply</p>  <p>A black power supply unit with a three-prong AC plug and a DC output cable with a barrel connector.</p>	<p>Pre - Paid meter pulse pickup</p>  <p>A white cable with a circular pulse pickup sensor at one end and two loose wires at the other.</p>	
<p>Additional Modules</p>		
<p>Hot Water</p>  <p>A white module with a red vertical label that says "Hot Water". It has a red LED indicator and a circular button.</p>	<p>Pool</p>  <p>A white module with a blue vertical label that says "Pool". It has a blue LED indicator and a circular button.</p>	<p>Irrigation</p>  <p>A white module with a green vertical label that says "Irrigation". It has a green LED indicator and two circular buttons.</p>

2 Installation

Decide where you would like to mount your Homebug Black Box. Mark out and drill two holes 40mm apart. Or alternatively mount with 2 way tape.

Route the Ethernet cable between your home router and the Homebug Black Box, and plug into a spare Ethernet port.

Plug the DC Power supply in to the Homebug Black box and plug the power supply into a plug socket.

You are now ready to configure your Homebug.

3 Configuration

Connect to the Homebug Local Web interface, the default IP address of the Homebug is 192.168.1.20

- 1 Connect your machine to the same network that the Homebug is connected to.
- 2 Open your web browser and type 192.168.1.20 into the address bar and press enter
- 3 If you are unable to browse to the Homebug Local Web interface set your computers IP address to 192.168.1.100 and try step 2 again.

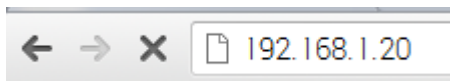

- 4 The following screen will be shown.

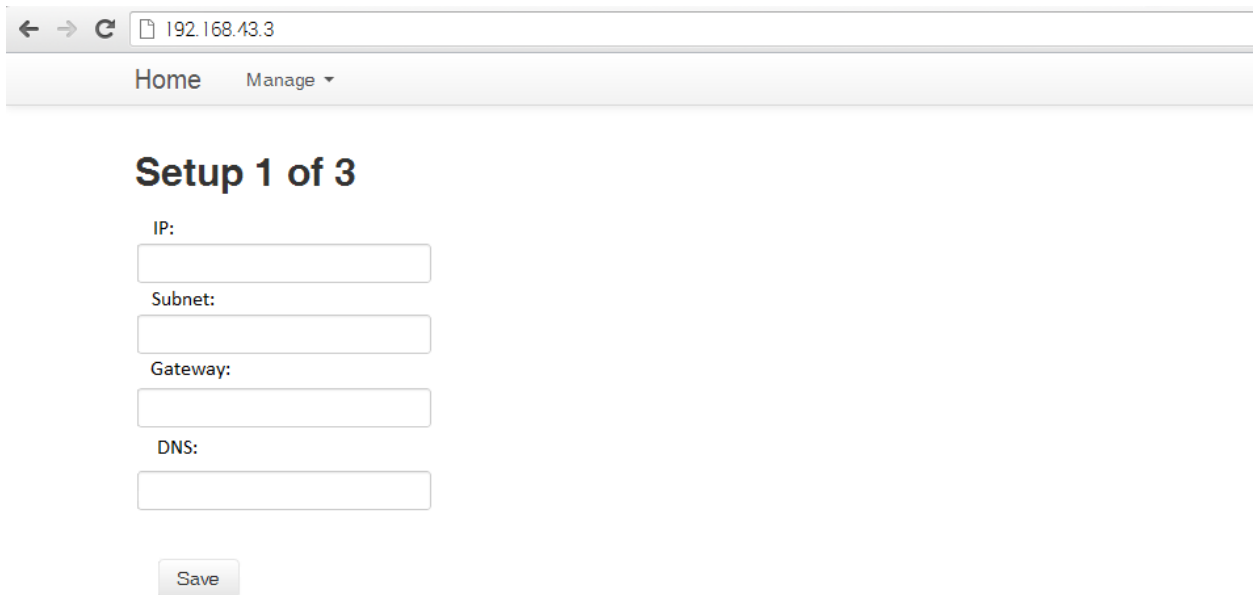
A screenshot of the Homebug Local Web interface. The browser address bar shows "192.168.43.3". The page has a navigation bar with "Home" and "Manage" (with a dropdown arrow). The main content area is titled "Setup 1 of 3" and contains four input fields labeled "IP:", "Subnet:", "Gateway:", and "DNS:". Below these fields is a "Save" button.

Home Manage ▾

Setup 1 of 3

IP:

Subnet:

Gateway:

DNS:

Save

- 5 Enter an available IP address in your network, the Gateway IP and DNS address.

Typically the Gateway IP Address and DNS are the same address

6 The Homebug will make the necessary changes and refresh the page when ready

7 The following screen will be shown

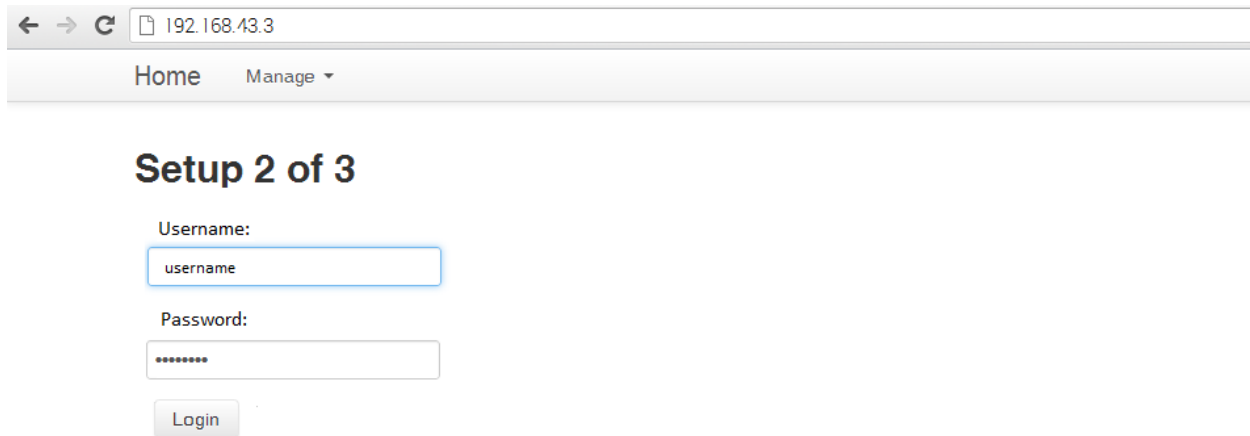

The screenshot shows a web browser window with the address bar containing '192.168.43.3'. Below the address bar, there is a navigation bar with 'Home' and 'Manage' (with a dropdown arrow). The main content area displays the title 'Setup 2 of 3' in bold. Below the title, there is a form with the following elements:

- A label 'Username:' followed by a text input field containing the text 'username'.
- A label 'Password:' followed by a password input field containing seven dots.
- A 'Login' button below the password field.

Enter your username and password, and click the login button. The Homebug will connect to the server and fetch all the available Homebugs under your account

This is the same username and password as the Homebug website.

If you are unable to login or access the Homebug on your entered IP Address , see reset procedure

- 8 Select from the Drop down, which Homebug is being configured.

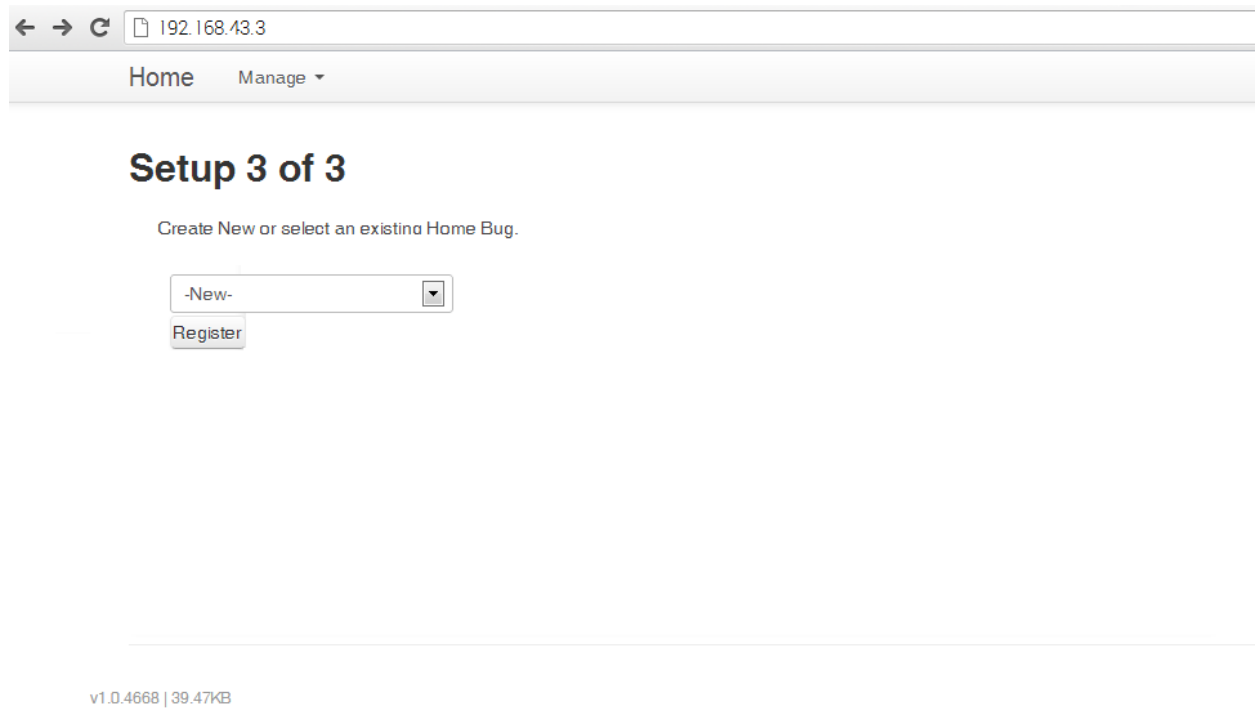

← → ↻ 192.168.43.3

Home Manage ▾

Setup 3 of 3

Create New or select an existing Home Bug.

-New- ▾

Register

v1.0.4668 | 39.47KB

If this is your first Homebug select New and click register.

- 9 The Homebug will collect all the parameters from the web server and refresh the page when ready
- 10 Your Homebug is now configured and ready for use.

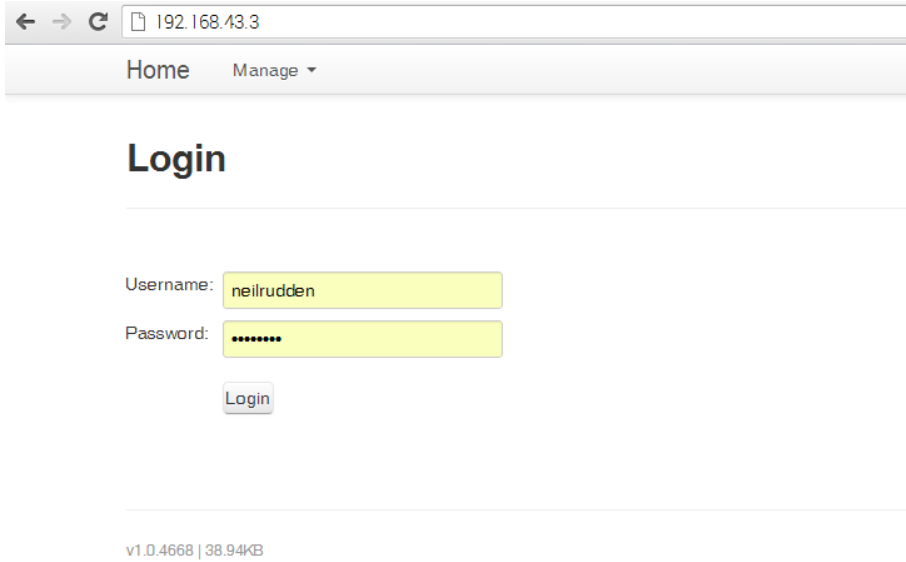

Click Logon

- 1 Congratulations you have successfully configured and logged onto the Homebug Local Web interface.

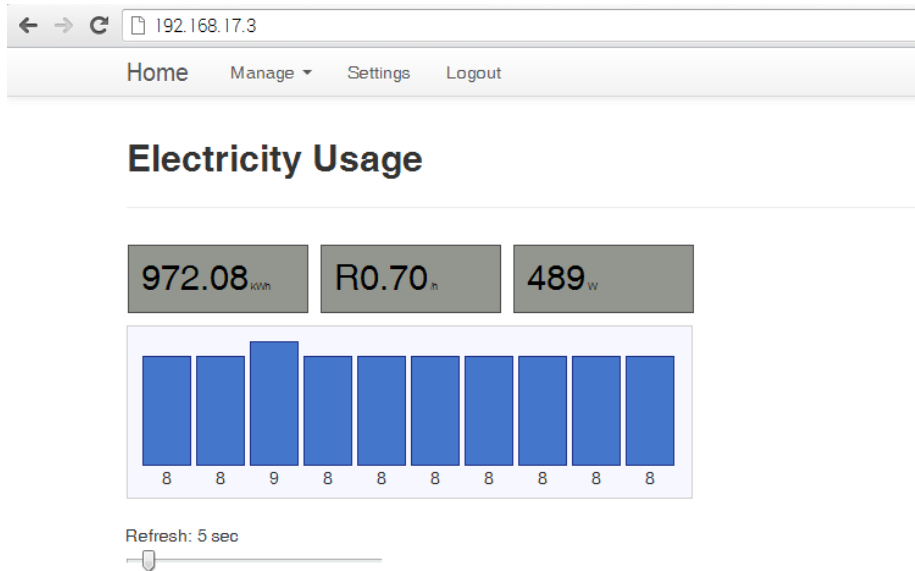

4 Electricity Usage

In order for the Homebug to report on your electricity usage we need to collect your energy usage from either your pre-paid meter or via an installed kWh meter.

4.1 Pre-Paid meter with LED Pulse output

If your home is fitted with a pre-paid meter the supplied pulse pickup needs to be positioned over the led/light on the meter.

Connect the black (wire with black heat shrink) to pin 1 of the 4 way pulse input connector and the white wire onto the pin 2 of the 4 way pulse input connector.

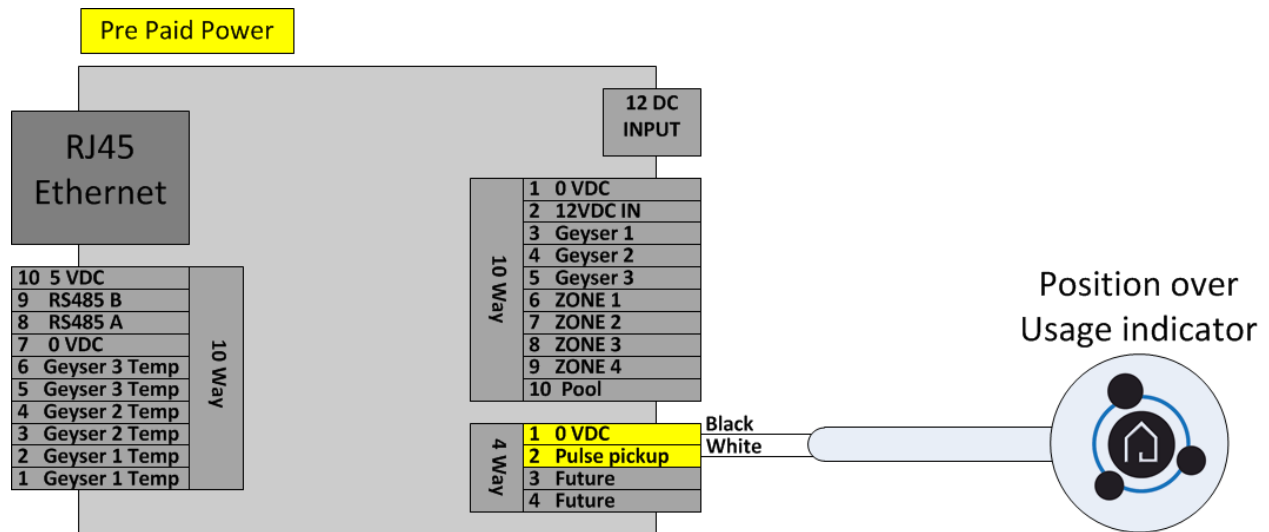

Take note of the number of pulses/kWh – default value is 1000 pulses/kWh

In order to confirm your pulse pickup is correctly installed see Calibrate flasher section

4.2 KWh meter Connection.

Fit the kWh meter as per manufacturer instructions in your electrical Distribution board (see supplied instructions with meter).

Connect the pulse output of the kWh meter to the Homebug as shown below.

This work needs to be done by a certified electrician

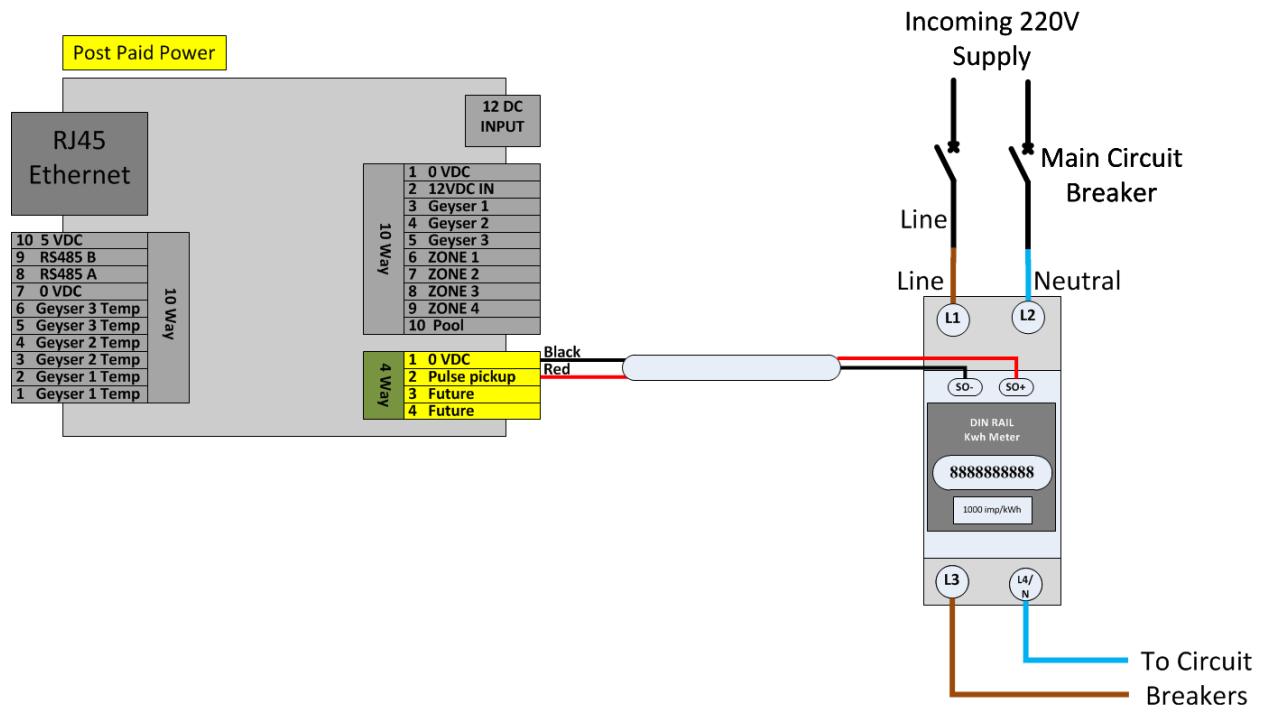

4.3 Calibrate Flasher

To calibrate the flasher, click on the settings menu to load the settings page, then click the Calibrate button.

Configuration

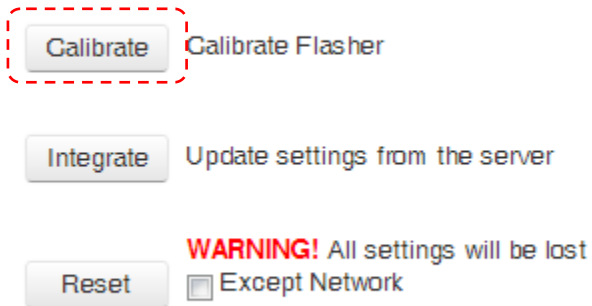

Calibrate Calibrate Flasher

Integrate Update settings from the server

Reset **WARNING!** All settings will be lost
 Except Network

The Homebug will now enter the test mode and will flash its LED whenever a pulse is received from the power meter. Confirm the pulses are all being shown. Once you have finished calibration, click done. This will exit the test mode.

Configuration

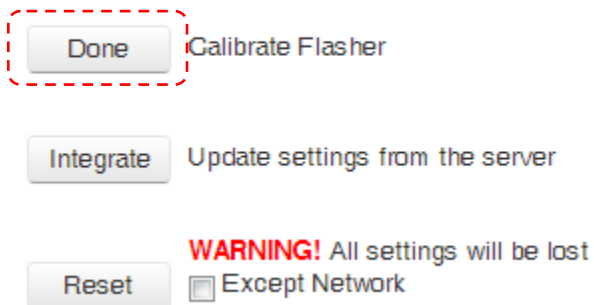

Done Calibrate Flasher

Integrate Update settings from the server

Reset **WARNING!** All settings will be lost
 Except Network

5 Hot Water

The Homebug is able to control 3 hot water cylinders. The connections are shown below. The diagram only shows the connection of geyser 1. Geysers 2 and 3 are wired into the respective numbered terminals in the same manner. The geyser can be run in timer mode - no temperature sensors are required.

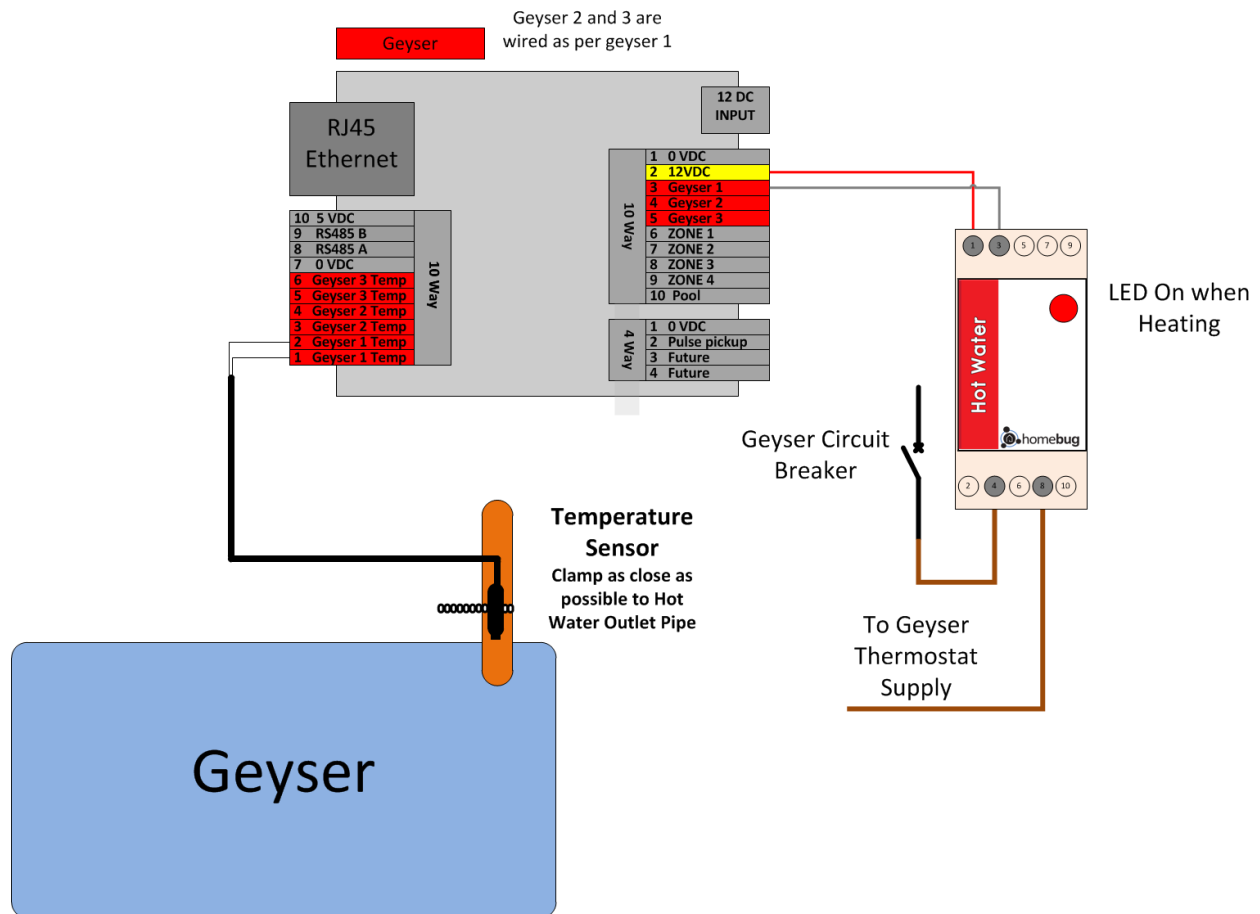

This work needs to be done by a certified electrician

Create a temporary Hot Water rule to test the installation. This is done via the manage hot water menu option.

6 Pool

The Homebug is able to control when your pool pump runs. Connect as per the diagram below.

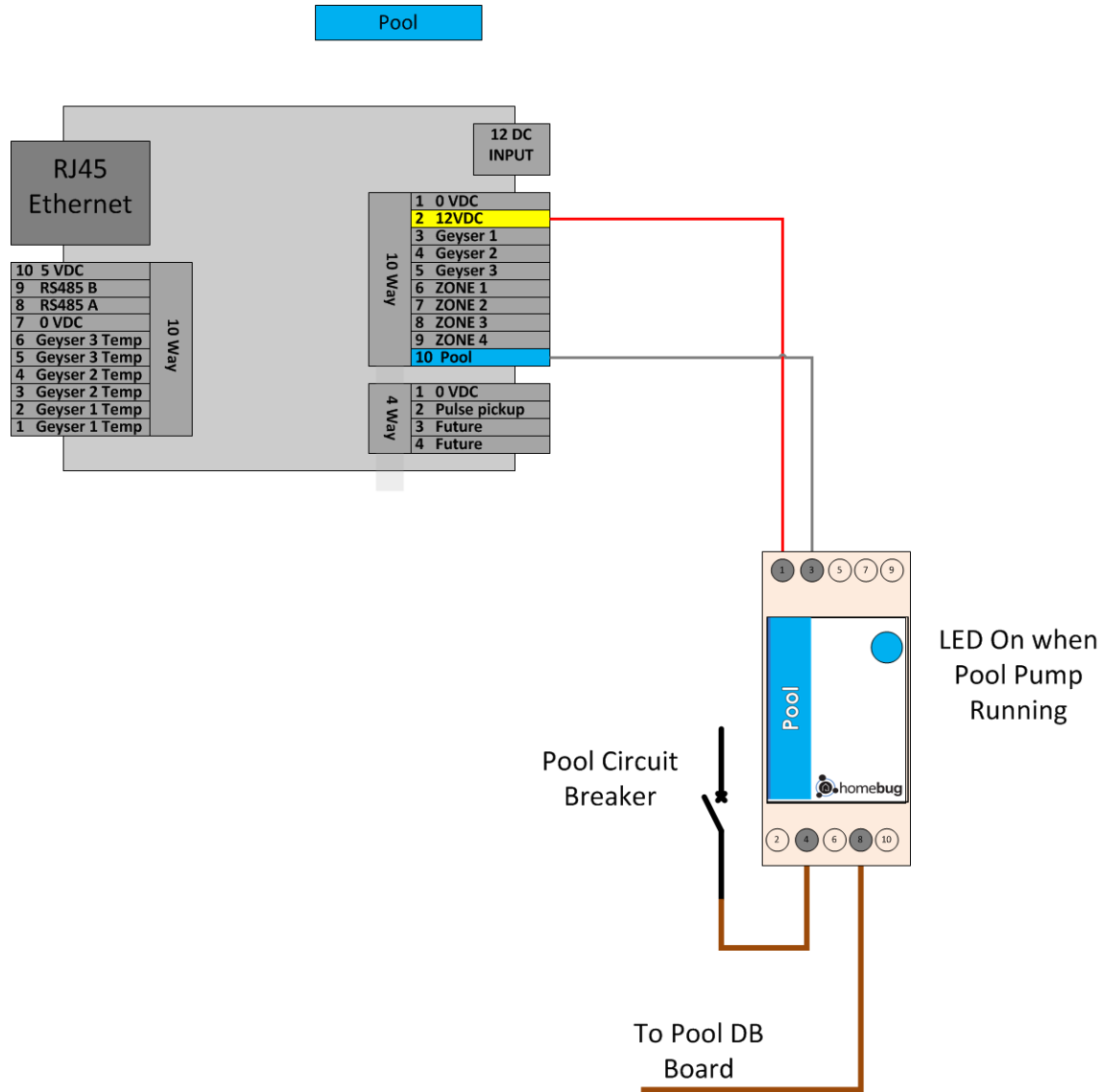

This work needs to be done by a certified electrician

Create a temporary Pool rule to test the installation. This is done via the manage pool menu option.

7 Irrigation

Homebug is able to control 4 irrigation zones. Connect as per the diagram below.

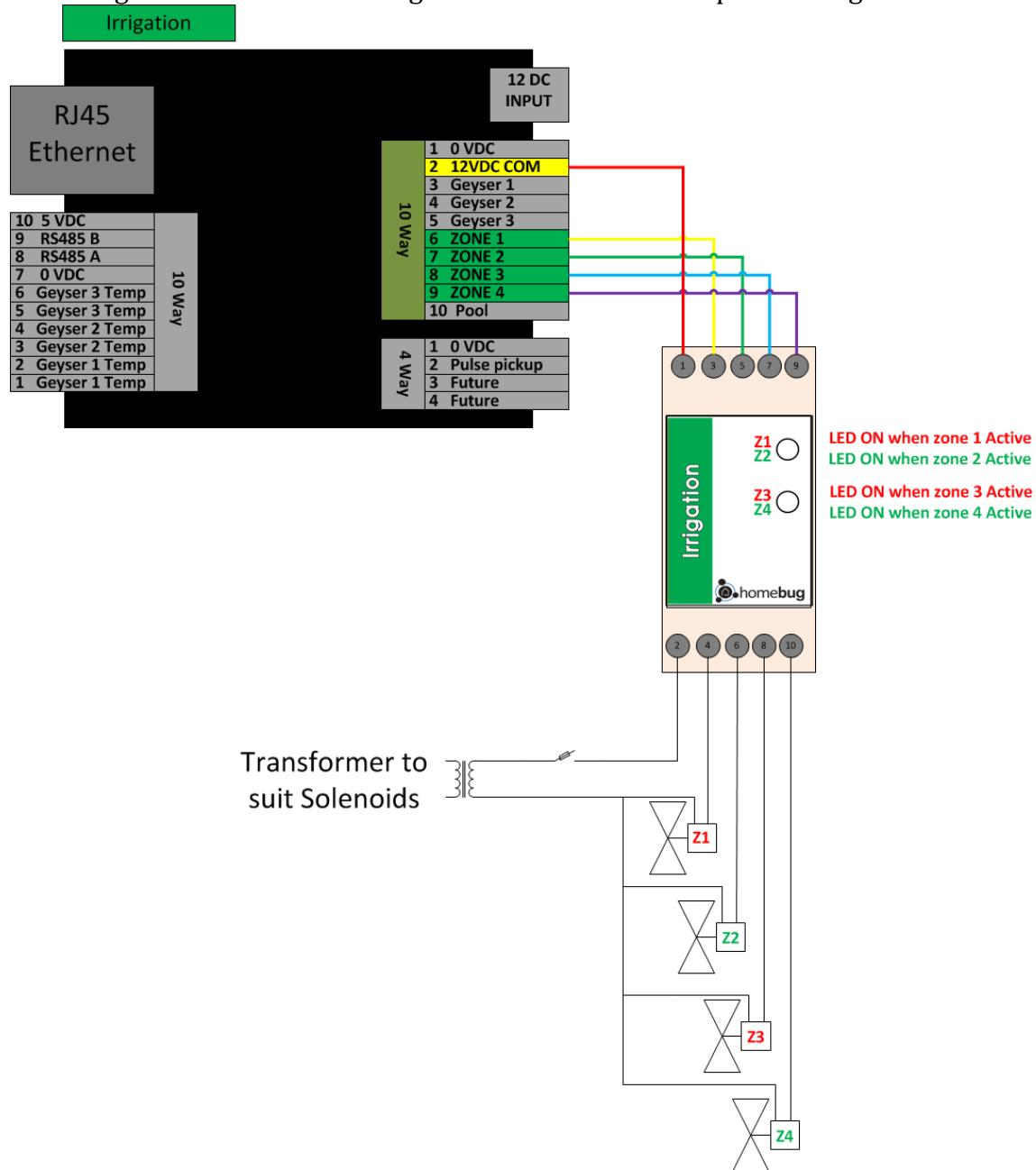

Create a temporary irrigation rule to test the installation. This is done via the manage irrigation menu option.

8 Lighting

The Homebug connects to the lighting modules over a serial communications bus. Multiple devices can be connected together in a chain, see the connection drawing below.

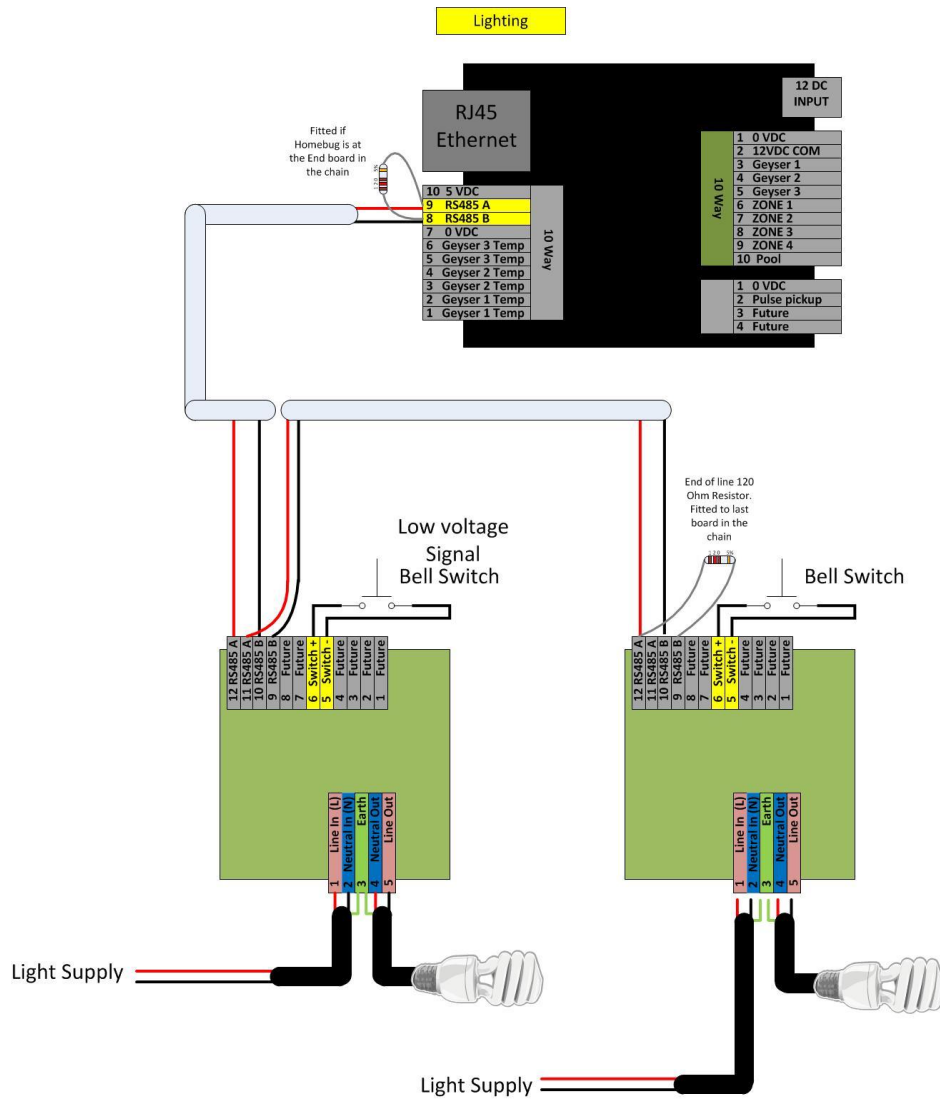

8.1 Lighting Setup

Once the lighting module has been wired into the Homebug it is ready to test.

To test if the light has been connected properly a press of the bell switch will turn the light on and another press will turn it off.

Once you have confirmed this is time to setup the communications to the Homebug.

When the module is delivered it has an address of '0'. To test the communications and wiring follow the steps below.

- 1 Open your web browser and type 192.168.1.20 into the address bar and press enter.
(or the address you setup in Section 1)
- 2 Login to the Local User interface
- 3 Click the manage menu option and select lighting.
- 4 Enter address 0 in the light address box and click on
- 5 If the communications channel is wired correctly you will see the light turn on

9 Troubleshooting

9.1 FAQ

Follow this link to the FAQ on the Homebug website which will have common issues and solutions.

<http://www.homebug.co.za/faq/>

9.2 Hardware Reset Procedure

This procedure is only available for errors during initial configuration. Once a Homebug has been allocated, this function is disabled.

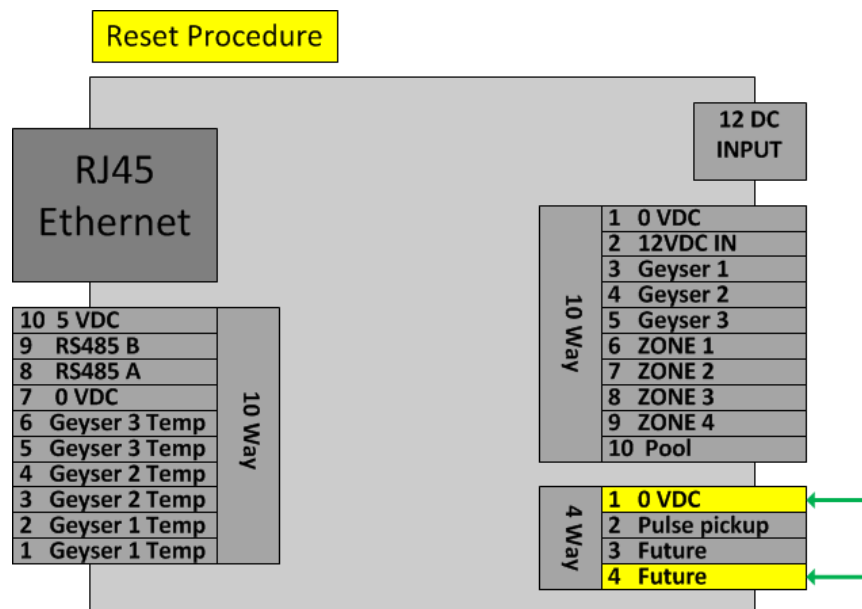

- 1 Disconnect power from the Homebug.
- 2 Connect any piece of wire between pin 1 and pin 4 of the 4way connector as shown.
- 3 Connect power to the Homebug
- 4 Wait until LED starts flashing quickly (approx. 10 seconds)
- 5 Disconnect power from the Homebug.
- 6 Remove the wire inserted in step 2
- 7 Connect power to the Homebug
- 8 The Homebug has been reset to factory defaults, please follow procedure in the configuration section.

Be sure to check the website as we add functionality and modules. Please feel free to contact Homebug with any queries or suggestions.

Neil Rudden
074 131 7625
021 554 1171
neil@homebug.co.za
www.homebug.co.za